

1		2		3		4		5		6		7		8		9		10		11		12		13		14		15	
A	旋台直徑 Worktable diameter		ø320 mm																										
	中心孔直徑 Center bore diameter		ø70H7																										
	工作台高度 Height of table		355 mm																										
B	中心高度 Height of center		255 mm																										
	工作台T型槽寬度 Width of T-slot		14H7 mm																										
	最大工件負載 MAX. loading capacity		200kg(In horizontal)/150kg(In tilt)																										
C	軸向 Axis	旋轉軸 Rotary		傾斜軸 Tilt																									
	伺服馬達型式 (選配) Servo motor	FANUC	A8I	A12I																									
D	齒數比 Transmission ratio	1:120																											
	最高迴轉數 MAX. table speed	16.6 rpm		11.1 rpm																									
E	最小設定單位 Resolution	0.001°																											
	分度精度(光學尺) Indexing accuracy	15"		50"																									
F	重複精度 Repeatability	6"		8"																									
	可傾斜角度 Tilting angle range	+30° ~ -120°																											
G	剎車鎖緊力 Clamping torque	118 Kg-m		118 Kg-m																									
	容許切削扭矩 Allowable cutting torque	40 Kg-m																											
	油壓剎車源 Hyd pressure	50 Kg/cm ²																											

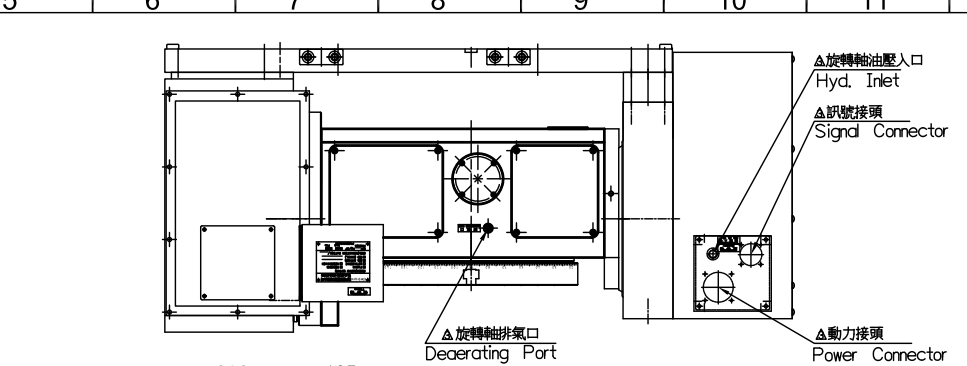

客戶確認用章 Customer confirmation	
核准 Approbation	審核 Audit

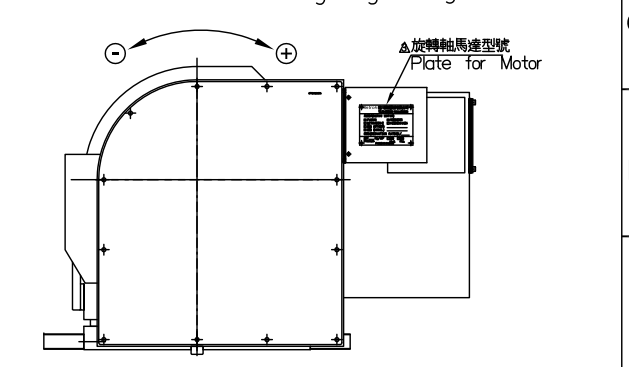
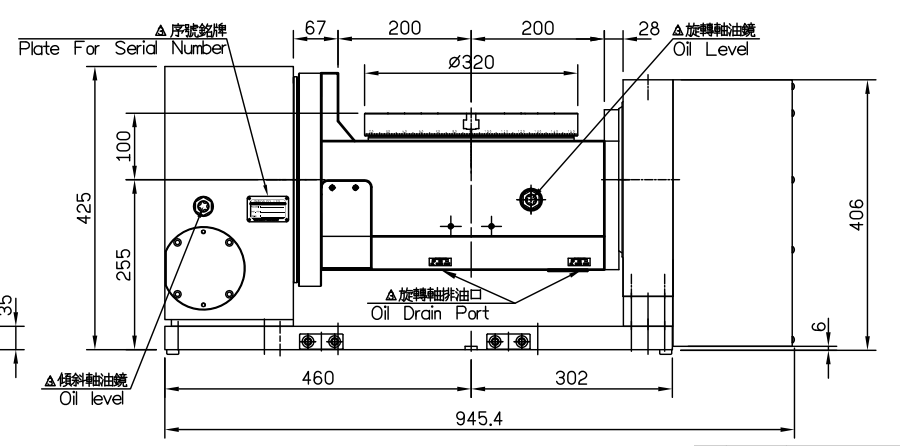
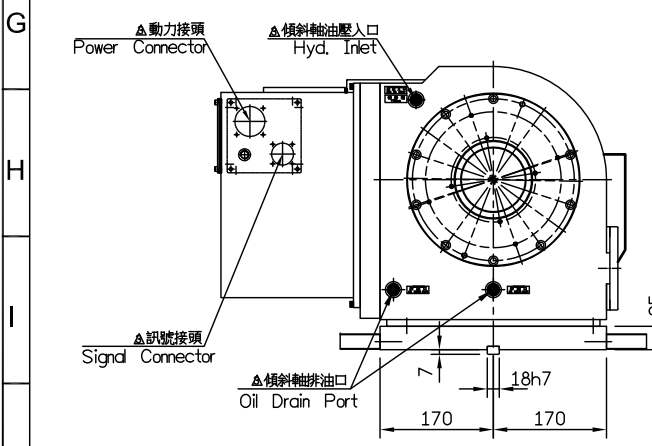
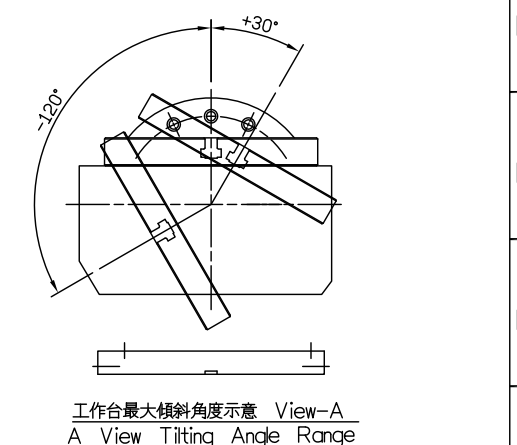
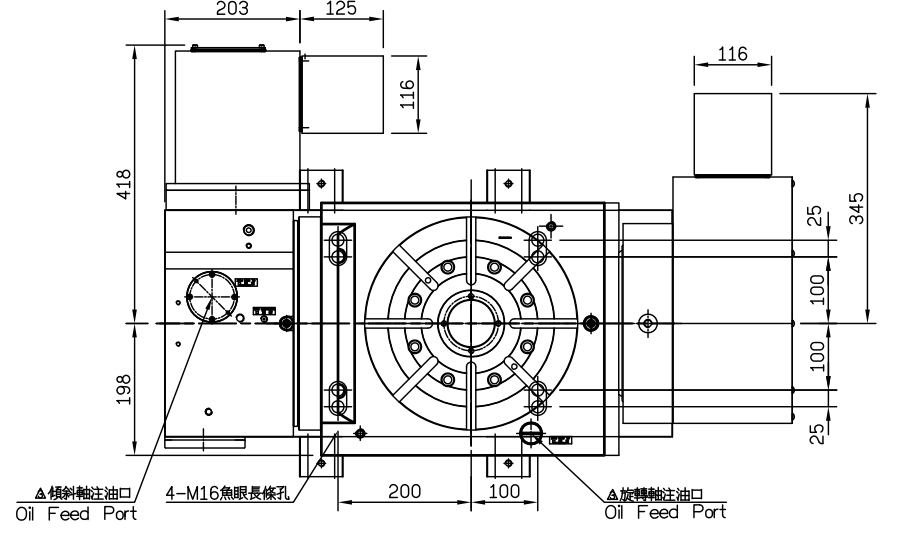
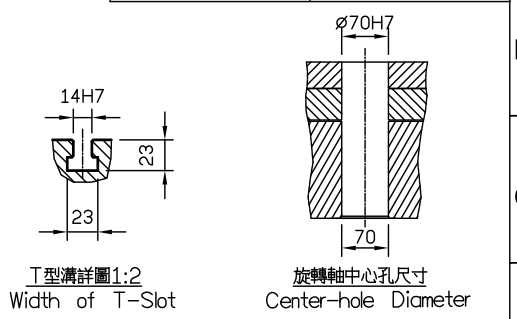

比例 SCALE		圖號 MODEL		材質 MATERIAL		名稱 TITLE		料號 PART NO.	
1=6		GF320H				五軸加工機		GF320H-A03	
角法 SKIAGRAPHY		用途 UNIT		備註 REMARKS		校準		繪圖	
1/台									
A 06'07'11		日期 DATE		新增圖樣, 變更所加英文		ITEM DESCRIPTION		SHEET 1 OF 1	
A2									